

NOTES:

1. HOLES AND INTERFACE DIMENSIONS PER MIL-PRF-83513/2.
2. MATEABLE WITH CONNECTORS MANUFACTURED PER MIL-PRF-83513/1 AND MIL-PRF-83513/3.
3. DESIGNED TO BE LASER WELDED TO 304L STAINLESS STEEL HOUSINGS.
4. HERMETIC LEAK RATE: LESS THAN OR EQUAL TO  $1 \times 10^{-9}$  CC/SEC He AT 1 ATM DIFFERENTIAL PRESSURE.
5. ELECTRICAL REQUIREMENTS:
  - INSULATION RESISTANCE: GREATER THAN 5,000 MEGOHMS AT  $500 \pm 10\%$  VDC AT 25°C WHEN TESTED IAW MIL-STD-1344, METHOD 3003.
  - DIELECTRIC WITHSTANDING VOLTAGE: MUST SHOW NO EVIDENCE OF BREAKDOWN OR FLASHOVER WHEN SUBJECTED TO 600 VAC RMS 60Hz IAW MIL-STD-1344, METHOD 3001. DURATION OF APPLICATION TO BE 1 SEC MIN.
6. MATERIALS:
  - SHELL: 304L STAINLESS STEEL IAW QQ-S-763.
  - CONTACTS: BERYLLIUM-COPPER IAW ASTM B196/B197.
  - INSULATORS: KRYOFLEX 313 PROPRIETARY POLYCRYSTALLINE CERAMIC.
  - INTERFACIAL SEAL: FLUOROSILICONE RUBBER IAW MIL-R-25988, CLASS I, TYPE II, GRADE 60.
7. FINISH:
  - CONTACTS: ELECTROLYTIC NICKEL PLATE IAW QQ-N-290, .000100/.000250 THICK.
  - GOLD PLATE IAW ASTM B488, TYPE III, GRADE A OR MIL-G-45204, TYPE III, GRADE A, .000050/.000150 THICK.

8. ORDERING INFORMATION:  
PLEASE SPECIFY ACCORDING TO THE FOLLOWING

93042 - X

PIN COUNT  
(9, 15, 21, 25, 31, OR 37)

NUMBER OF CONTACTS	W	Y	Z
9	.565	.420	.423
15	.715	.570	.573
21	.865	.720	.723
25	.965	.820	.823
31	1.115	.970	.973
37	1.265	1.120	1.123

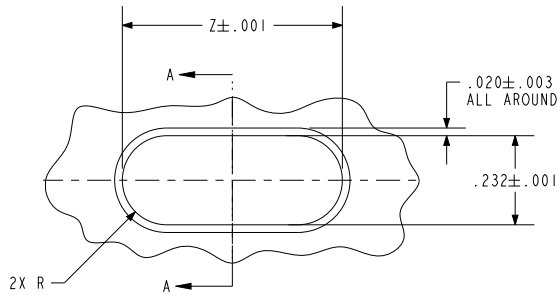
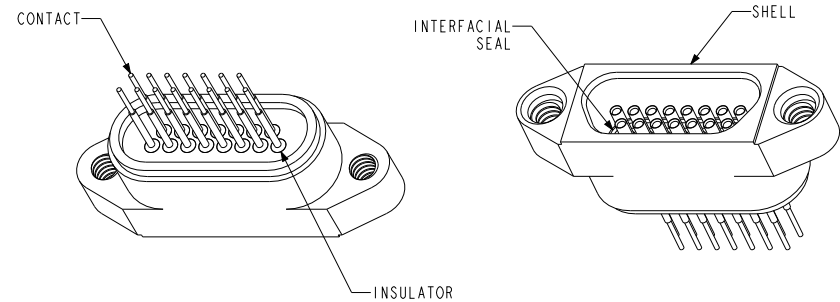
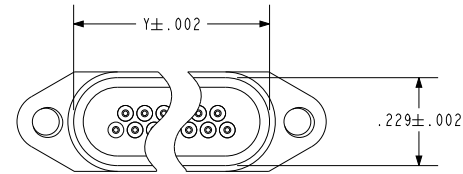
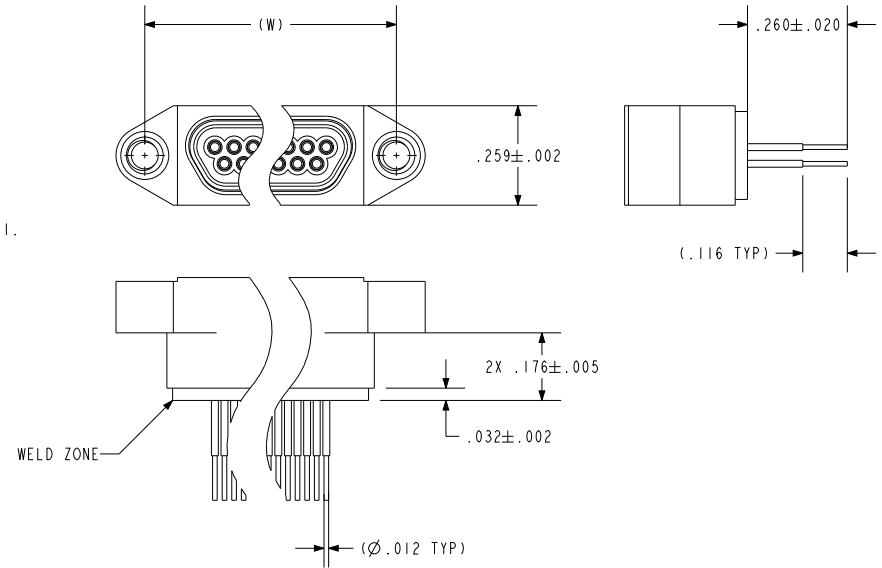

HOLE DETAIL

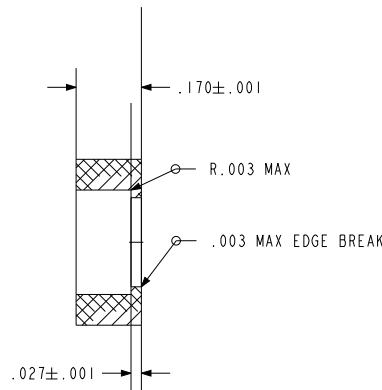

SECTION A-A

**P&E** 434 Olds Station Rd. Wenatchee, Washington 98801  
WWW.PACAERO.COM

TITLE: CONNECTOR, MICRO-D, STD-PROFILE, SST-COMPATIBLE, STEPPED LEADS  
CAGE CODE: 64567

VERSION: A.1 RELEASE DATE: 01-23-08 SHEET: 1 OF 1 DOCUMENT: 0-93042

SALES DRAWING