

NOTES:

1. HERMETIC LEAK RATE: LESS THAN OR EQUAL TO 1×10^{-9} CC/SEC He AT 1 ATM DIFFERENTIAL PRESSURE.
2. NOMINAL IMPEDANCE: 50 OHMS.
3. INSULATION RESISTANCE: 5000 MEGOHMS MINIMUM.
4. DESIGNED TO BE LASER WELDED INTO ALUMINUM 6061 HOUSINGS.
5. MATERIALS:
 WELD FLANGE: 4000 SERIES ALUMINUM.
 CONTACT: KOVAR IAW ASTM-F15 OR MIL-I-23011.
 INSULATOR: 7070 CORNING GLASS OR EQUIVALENT.
 GROUND SPRING: S.S.T. IAW ASTM-A276 OR QQ-S-763.
6. FINISH:
 NICKEL PLATE IAW ASTM B733, TYPE I, CLASS 4, .000100/.000250 THICK.
 GOLD PLATE IAW ASTM B488, TYPE III, CODE A, .000050/.000150 THICK.
 WELD FLANGE: CONVERSION COATED IAW MIL-C-5541, CL 1A
7. ORDERING INFORMATION:
 PLEASE SPECIFY ACCORDING TO THE FOLLOWING:

92613 - 130 - 050 - 035

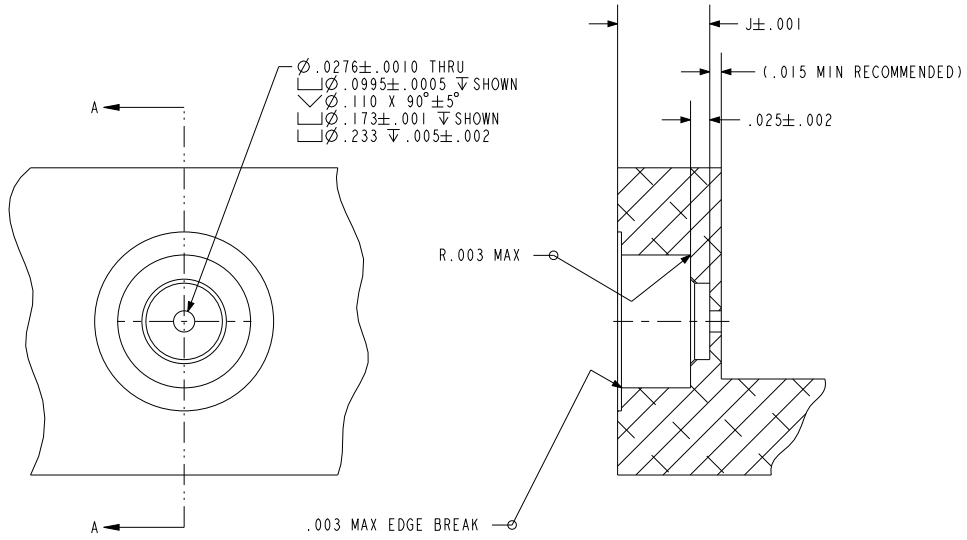
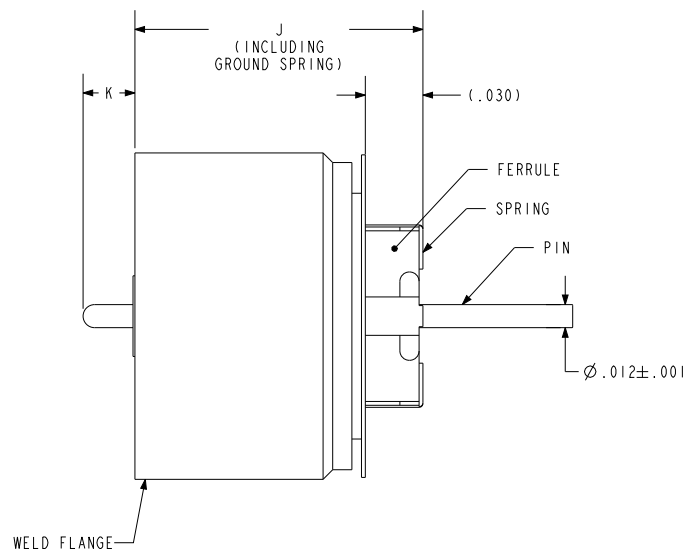
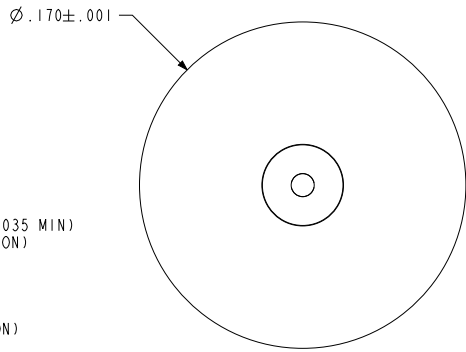
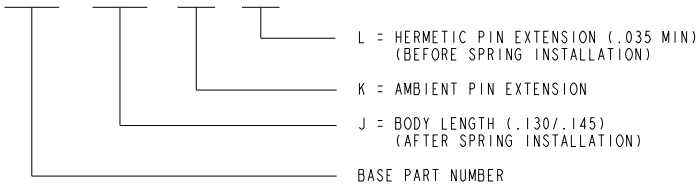

SCALE 4.000

HOLE DETAIL



SCALE 2.000

PACERO
 A Division of
HERMETIC SOLUTIONS
 The Hermetic Advantage
 Enabling Technology
 434 Olds Station Rd. Wenatchee WA 98801

WWW.PACERO.COM

TITLE: ALUMINUM LASER WEDABLE .012 FLANGE MOUNT RF CONNECTOR

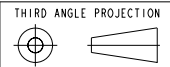

CAGE CODE: 64567

VERSION: Y.0
 RELEASE DATE: 01-22-08

SALES DRAWING

SHEET: 1 OF 1

DOCUMENT: 0-92613