

NOTES:

1. HOLES AND INTERFACE DIMENSIONS PER MIL-DTL-24308.
2. MATEABLE WITH CONNECTORS MANUFACTURED PER MIL-DTL-24308.
3. DESIGNED TO BE LASER WELDED INTO ALUMINUM HOUSINGS.
4. HERMETIC LEAK RATE: LESS THAN OR EQUAL TO  $1 \times 10^{-9}$  CC/SEC He AT 1 ATM DIFFERENTIAL PRESSURE.
5. ELECTRICAL REQUIREMENTS:  
 INSULATION RESISTANCE: GREATER THAN 5,000 MEGOHMS AT  $500 \pm 10\%$  VDC AT  $25^\circ\text{C}$  WHEN TESTED IAW MIL-STD-1344, METHOD 3003.  
 DIELECTRIC WITHSTANDING VOLTAGE: MUST SHOW NO EVIDENCE OF BREAKDOWN OR FLASHOVER WHEN SUBJECTED TO 600 VAC RMS 60Hz IAW MIL-STD-1344, METHOD 3001. DURATION OF APPLICATION TO BE 1 SEC MIN.
6. MATERIALS:  
 SHELL: EXPLOSION BONDED STAINLESS STEEL TO 4XXX-SERIES ALUMINUM.  
 CONTACTS: BERYLLIUM-COPPER IAW ASTM B196/B197.  
 INSULATORS: KRYOFLEX 313 PROPRIETARY POLYCRYSTALLINE CERAMIC.  
 HELICAL INSERTS: 300-SERIES STAINLESS STEEL.
7. FINISH:  
 CONTACTS: ELECTROLYTIC NICKEL PLATE IAW QQ-N-290, .000100/.000250 THICK.  
 GOLD PLATE IAW ASTM B488, TYPE III, CODE A OR MIL-G-45204, TYPE III, GRADE A, .000100/.000150 THICK.  
 SHELL: CHEMICAL CONVERSION COAT PER MIL-C-5541, CLASS IA.
8. ORDERING INFORMATION:  
 PLEASE SPECIFY ACCORDING TO THE FOLLOWING: 93513-1

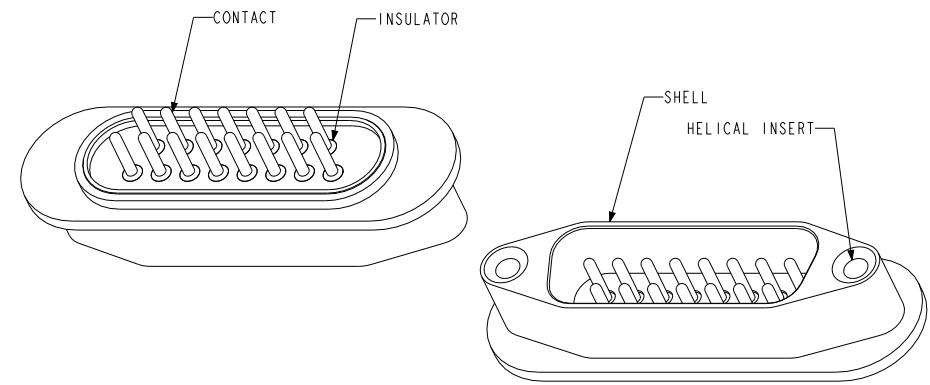
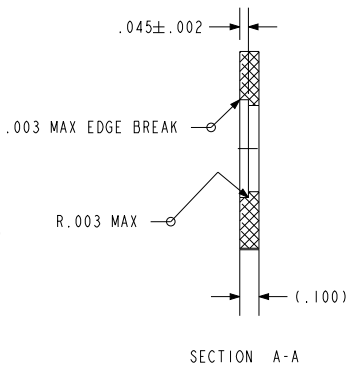
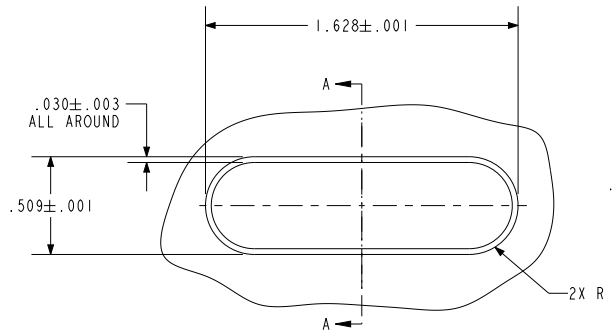
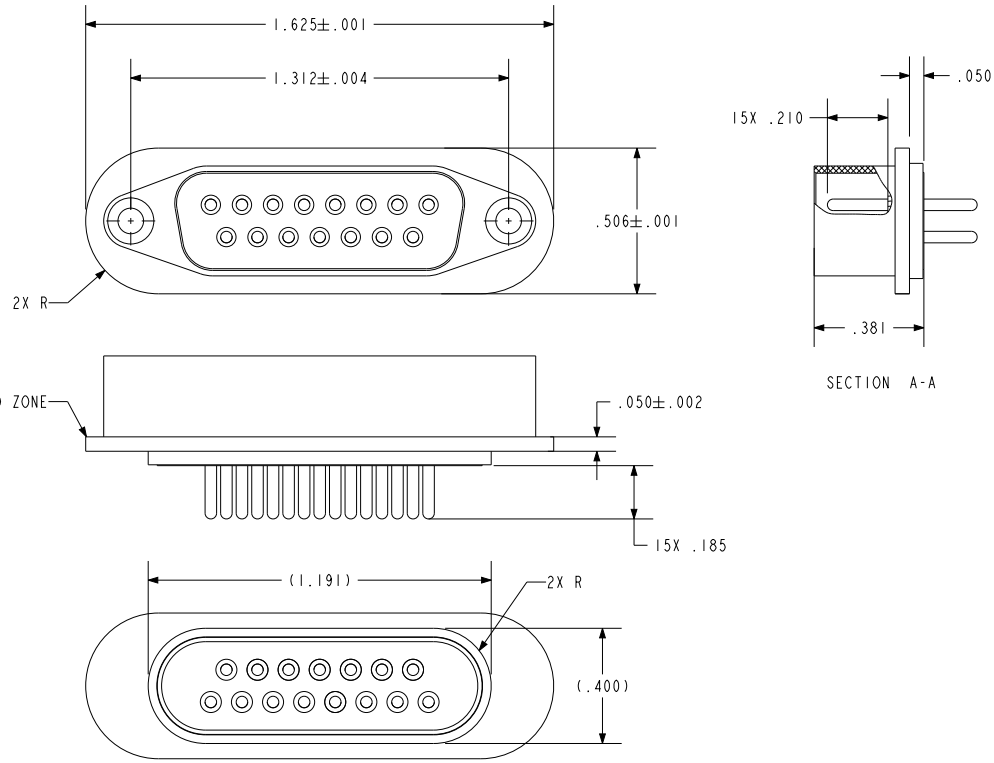

SCALE 1.000

HOLE DETAIL

**PA&E** A Division of **HERMETIC SOLUTIONS**  
 434 Olds Station Rd. Wenatchee WA 98801

TITLE: CONNECTOR, SUB-D, 15-PIN, AL COMPATIBLE, SIZE 2, ARRANGEMENT I

THIRD ANGLE PROJECTION

CAGE CODE: 64567

VERSION: -.0  
 RELEASE DATE: 01-26-09

**SALES DRAWING**

SHEET: 1 OF 1

DOCUMENT: 0-93513