

NOTES:

1. INTERFACE PER MIL-STD-348.
2. HERMETIC LEAK RATE: LESS THAN OR EQUAL TO 1×10^{-9} CC/SEC He AT 1 ATM DIFFERENTIAL PRESSURE.
3. NOMINAL IMPEDANCE: 50 OHMS.
4. INSULATION RESISTANCE: 5000 MEGOHMS MINIMUM.
5. DESIGNED TO BE LASER WELDED INTO TITANIUM HOUSINGS.
6. MATERIALS:
 WELD FLANGE: TITANIUM.
 CONTACT: KOVAR 1AW ASTM-F15 OR MIL-1-23011.
 INSULATOR: 7070 CORNING GLASS OR EQUIVALENT.
 GROUND SPRING: BeCu-172/173 1AW ASTM-B194, TD04.
7. FINISH:
 NICKEL PLATE 1AW ASTM B733, TYPE I, CLASS 4, .000100/.000250 THICK.
 GOLD PLATE 1AW ASTM B488, TYPE III, CODE A, .000050/.000150 THICK.
8. ORDERING INFORMATION:
 PLEASE SPECIFY ACCORDING TO THE FOLLOWING:

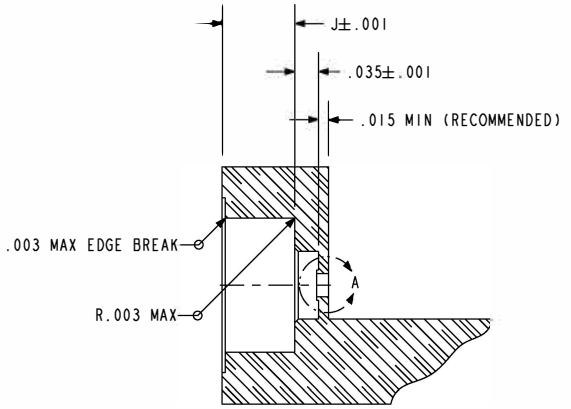

SECTION A-A

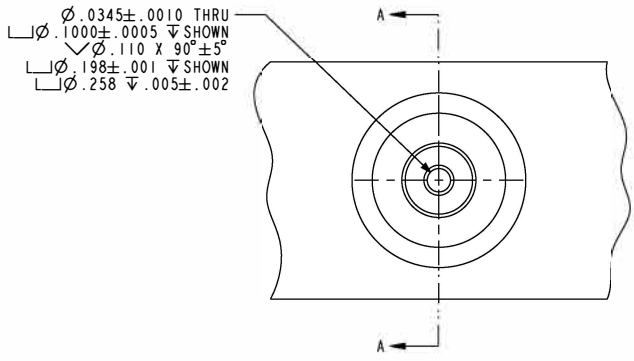
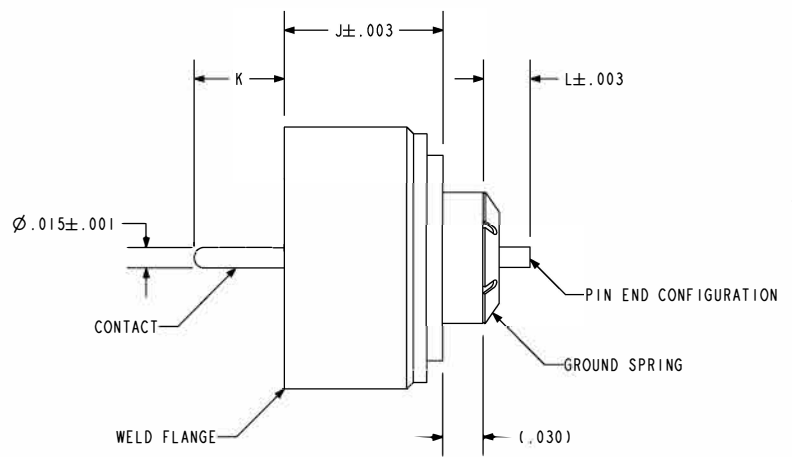
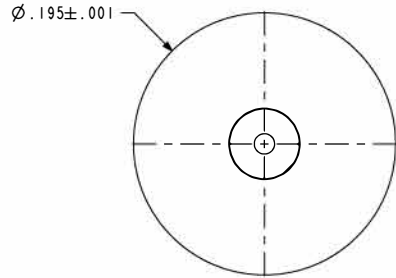
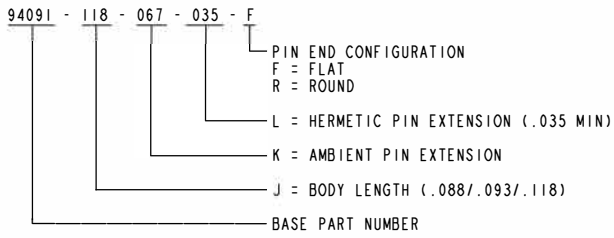

SCALE 2.000
(94091-118-067-035-F SHOWN)

HOLE DETAIL

SCALE 3.500

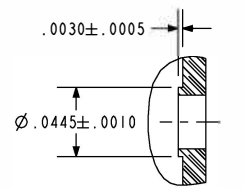

DETAIL A
SCALE 8.000

PACAE A Division of **HERMETIC SOLUTIONS**
The Helium Advantage Quality Technology

434 Olds Station Rd. Wenatchee WA 98801

WWW.PACAERO.COM

TITLE: CONNECTOR, RF, FLANGE MOUNT, TI-COMPATIBLE		THIRD ANGLE PROJECTION 	
VERSION: 1		CAGE CODE: 64567	
RELEASE DATE: 01-06-11		DOCUMENT: 0-94091	
SALES DRAWING		SHEET: 1 OF 1	