

NOTES:

- INTERFACE DIMENSIONS PER MIL-PRF-83513/2.
- MATEABLE WITH CONNECTORS MANUFACTURED PER MIL-PRF-83513/1 AND MIL-PRF-83513/3.
- DESIGNED TO BE LASER WELDED TO A 304L S.ST. HOUSING.
- HERMETIC LEAK RATE: LESS THAN OR EQUAL TO  $1 \times 10^{-9}$  CC/SEC He AT 1 ATM DIFFERENTIAL PRESSURE.
- ELECTRICAL REQUIREMENTS:
  - INSULATION RESISTANCE: GREATER THAN 5,000 MEGOHMS AT  $500 \pm 10\%$  VDC AT 25°C WHEN TESTED IAW MIL-STD-1344, METHOD 3003.
  - DIELECTRIC WITHSTANDING VOLTAGE: MUST SHOW NO EVIDENCE OF BREAKDOWN OR FLASHOVER WHEN SUBJECTED TO 600 VAC RMS 60Hz IAW MIL-STD-1344, METHOD 3001. DURATION OF APPLICATION TO BE 1 SEC MIN.
- MATERIALS:
  - WELD FLANGE: 304L STAINLESS STEEL.
  - CONTACTS: BERYLLIUM-COPPER IAW ASTM B196 OR ASTM B197.
  - INSULATORS: KRYOFLEX 313 PROPRIETARY POLYCRYSTALLINE CERAMIC.
  - INTERFACIAL SEAL: FLUOROSILICONE RUBBER IAW MIL-R-25988, CLASS 1, TYPE II, GRADE 60.
- WIRE BOND FLATS SHALL BE .030 MIN. LONG AND .010 MIN. WIDE.

- FINISH:
  - CONTACTS: ELECTROLYTIC NICKEL PLATE IAW QQ-N-290, .000100/.000200 THICK.
  - GOLD PLATE IAW ASTM B488, TYPE III, GRADE A, .000100/.000175 THICK.

9. ORDERING INFORMATION:  
PLEASE SPECIFY ACCORDING TO THE FOLLOWING

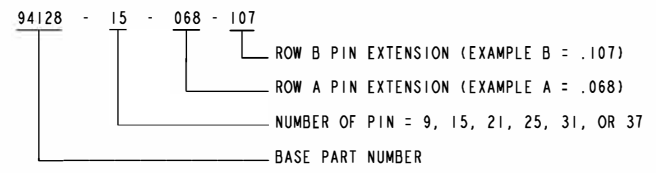

NUMBER OF CONTACTS	W	L	Y
9	.386	.389	.565
15	.536	.539	.715
21	.686	.689	.865
25	.786	.789	.965
31	.936	.939	1.115
37	1.086	1.089	1.265

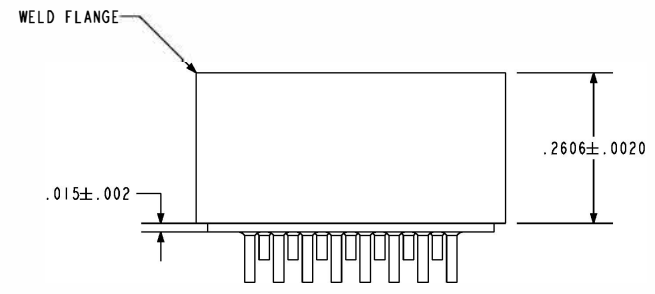
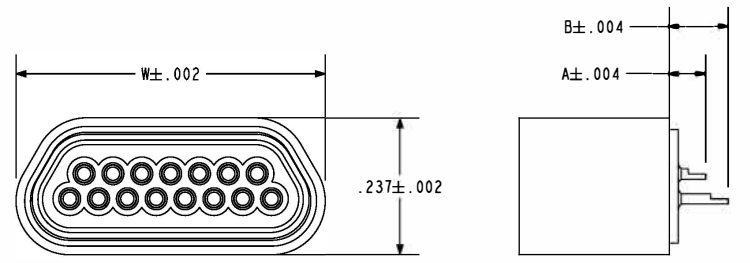
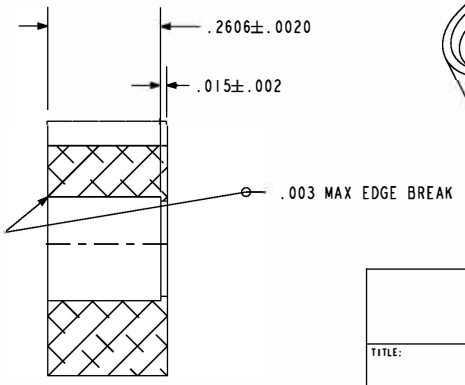
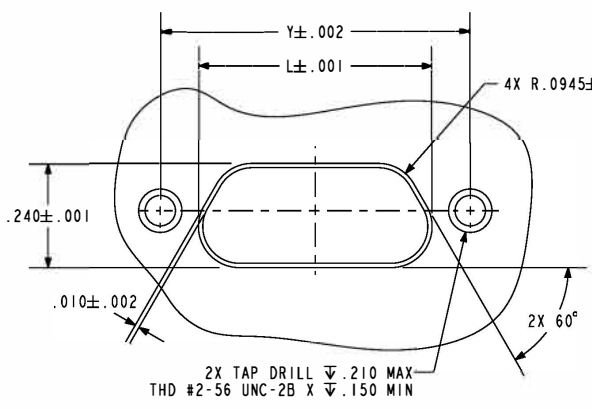

(-15 SHOWN)

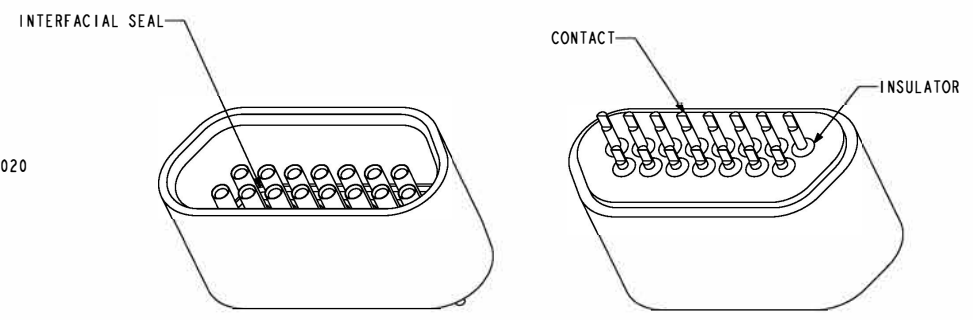

(-15 SHOWN)

**P&E** A Division of HERMETIC SOLUTIONS  
434 Olds Station Rd. Wenatchee WA 98801

WWW.PACAERO.COM

TITLE: CONNECTOR, MICRO-D, CUSTOM, S.ST. THIRD ANGLE PROJECTION  
CAGE CODE: 64567

RECOMMENDED HOLE DETAIL

VERSION: F.0 RELEASE DATE: 01-19-11

SALES DRAWING

SHEET: 1 OF 1

DOCUMENT: 0-94128