

NOTES:

1. HOLES AND INTERFACE DIMENSIONS PER MIL-PRF-83513/2.
2. MATEABLE WITH CONNECTORS MANUFACTURED PER MIL-PRF-83513/1 AND MIL-PRF-83513/3.
3. DESIGNED TO BE LASER WELDED TO AN ALUMINUM HOUSING.
4. WIRE BOND FLATS SHALL BE .030 MIN. LONG, .015 MIN. WIDE, AND .007 MIN. THICK.
4. HERMETIC LEAK RATE: LESS THAN OR EQUAL TO 1×10^{-9} CC/SEC He AT 1 ATM DIFFERENTIAL PRESSURE.
5. ELECTRICAL REQUIREMENTS:
 - INSULATION RESISTANCE: GREATER THAN 5,000 MEGOHMS AT $500 \pm 10\%$ VDC AT 25°C WHEN TESTED IAW MIL-STD-1344, METHOD 3003.
 - DIELECTRIC WITHSTANDING VOLTAGE: MUST SHOW NO EVIDENCE OF BREAKDOWN OR FLASHOVER WHEN SUBJECTED TO 600 VAC RMS 60Hz IAW MIL-STD-1344, METHOD 3001. DURATION OF APPLICATION TO BE 1 SEC MIN.
6. MATERIALS:
 - WELD FLANGE: 4XXX-SERIES ALUMINUM.
 - CONTACTS: BERYLLIUM-COPPER IAW ASTM B196 OR ASTM B197.
 - INSULATORS: KRYOFLEX 313 PROPRIETARY POLYCRYSTALLINE CERAMIC.
 - INTERFACIAL SEAL: FLUOROSILICONE RUBBER IAW MIL-R-25988, CLASS I, TYPE II, GRADE 60.
 - HELICAL INSERTS: 300-SERIES STAINLESS STEEL.
7. FINISH:
 - CONTACTS: ELECTROLYTIC NICKEL PLATE IAW QQ-N-290, .000100/.000250 THICK.
 - GOLD PLATE IAW MIL-G-45204, TYPE II, GRADE C, .000050/.000150 THICK.
 - SHELL: CHEMICAL CONVERSION COAT IAW MIL-C-5541, CLASS IA.
8. ORDERING INFORMATION:
 - PLEASE SPECIFY ACCORDING TO THE FOLLOWING
 - 94708 - 1

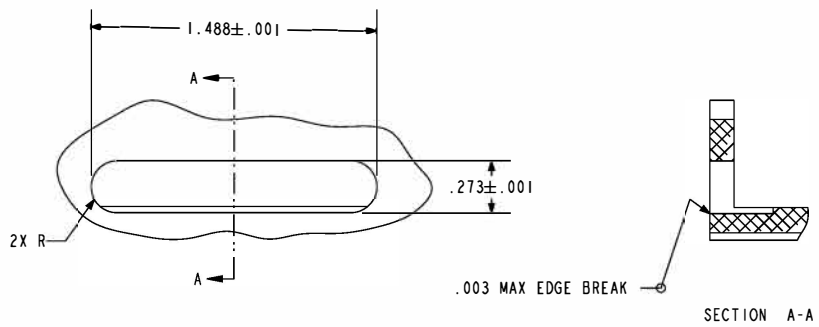

HOLE DETAIL

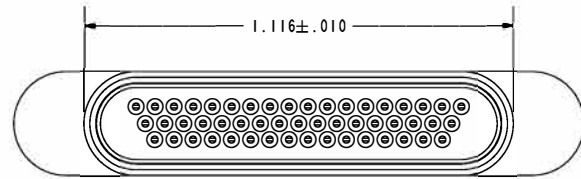
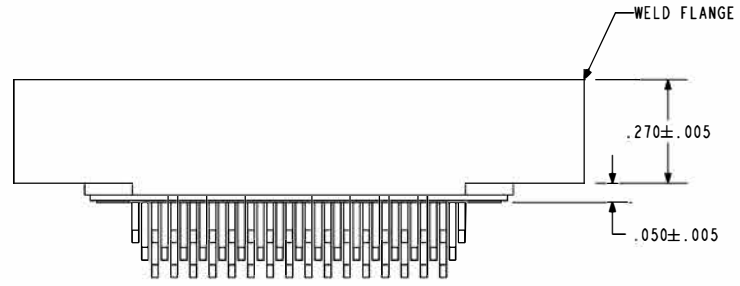
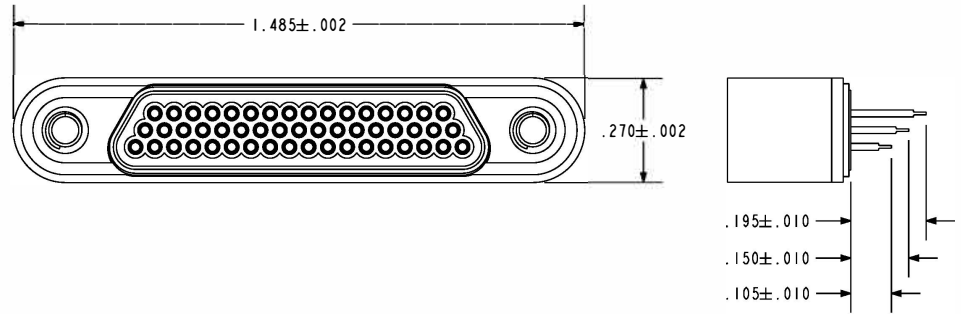
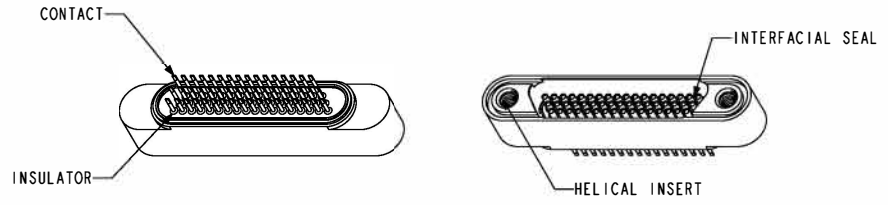

P&E A Division of HERMETIC SOLUTIONS
 434 Olds Station Rd. Wenatchee WA 98801

TITLE:	MICRO-D, 51-PIN, REVERSE STAGGERED LEADS	THIRD ANGLE PROJECTION
VERSION	- .0	CAGE CODE: 64567
RELEASE DATE:	01-04-11	DOCUMENT: 0-94708

SALES DRAWING

SHEET: 1 OF 1