

NOTES:

- DESIGNED TO BE LASER WELDED TO A TITANIUM HOUSING.
- HERMETIC LEAK RATE: LESS THAN OR EQUAL TO 1×10^{-9} CC/SEC H_2 AT 1 ATM DIFFERENTIAL PRESSURE.
- ELECTRICAL REQUIREMENTS:
 INSULATION RESISTANCE: GREATER THAN 5,000 MEGOHMS AT $500 \pm 10\%$ VDC AT $25^\circ C$ WHEN TESTED IAW MIL-STD-1344, METHOD 3003.
 DIELECTRIC WITHSTANDING VOLTAGE: MUST SHOW NO EVIDENCE OF BREAKDOWN OR FLASHOVER WHEN SUBJECTED TO 600 VAC RMS 60Hz IAW MIL-STD-1344, METHOD 3001. DURATION OF APPLICATION TO BE 1 SEC MIN.

4. MATERIALS:
 WELD FLANGE: GRADE 4 TITANIUM
 CONTACTS: 80XP1/20X1r
 INSULATOR: KRYOFLEX 313 PROPRIETARY POLYCRYSTALLINE CERAMIC.
 CAP BEAD: ALUMINA

5. ORDERING INFORMATION:
 PLEASE SPECIFY ACCORDING TO THE FOLLOWING

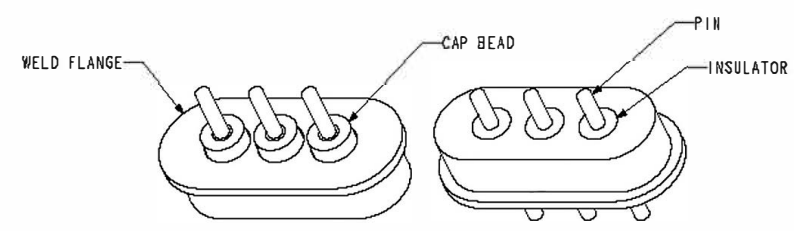
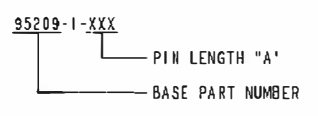

SCALE 1.000
 95209-1-071 SHOWN

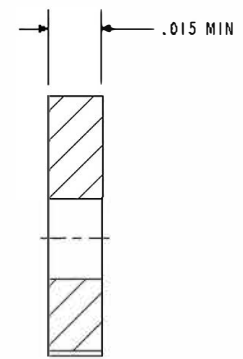
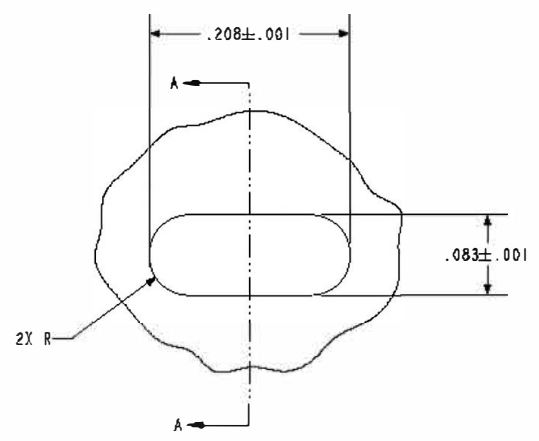
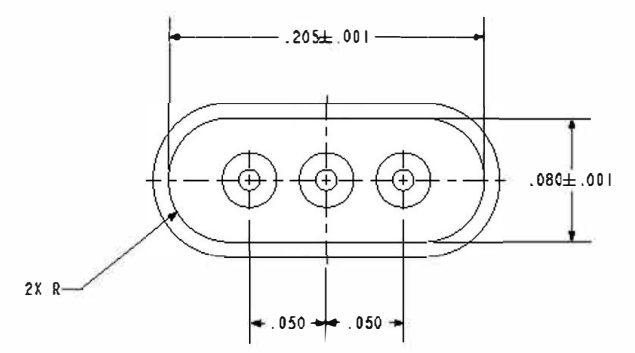
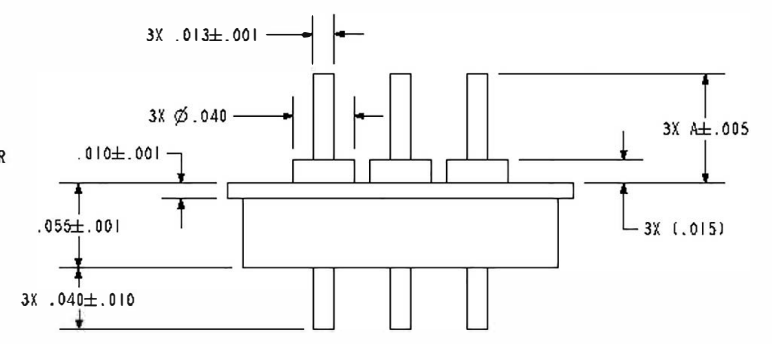
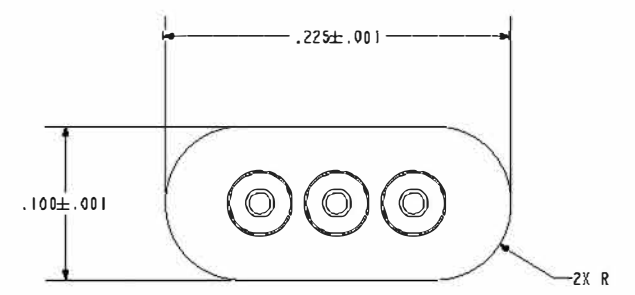

SUGGESTED HOLE DETAIL

SECTION A-A

		A Division of HERMETIC SOLUTIONS <i>Enabling Technology</i>	
434 Olds Station Rd. Wenatchee WA 98801			
TITLE:		FEEDTHRU, IMPLANTABLE, 3 PIN	
		JWC: EAR	
VERSION	RELEASE DATE:	CAGE CODE:	SCALE:
- . 0	08-04-14	64567	8.000
SALES DRAWING		SHEET:	DOCUMENT:
		1 OF 1	0-95209